

# Explorer X-13/X-19 Educational

Flying Model Rocket Kit Instructions

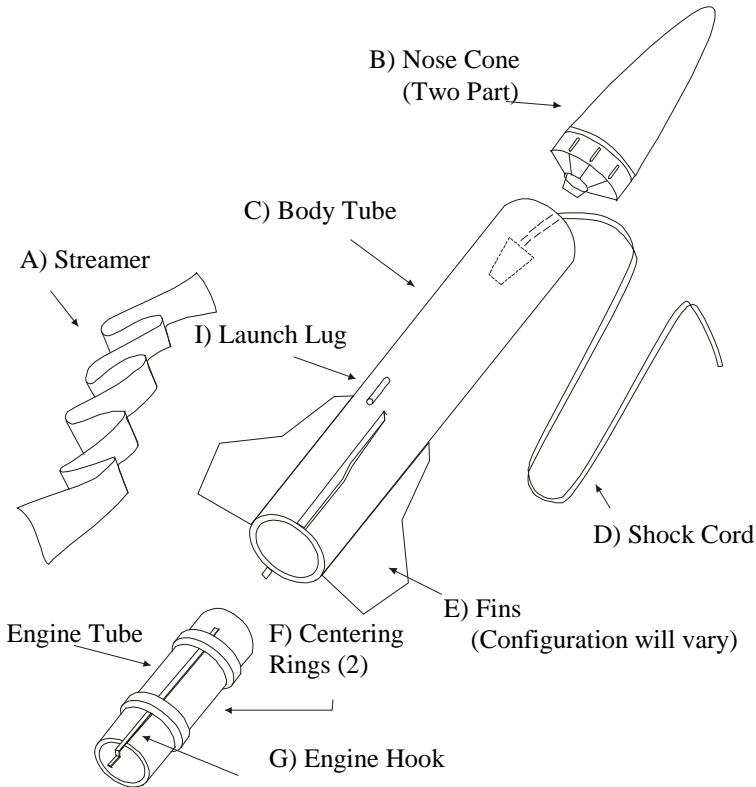

## Expanded View



## How to Use These Instructions:

- Using basic modeling techniques, this kit will help in the development of modeling skills.
- Check all parts before you begin building.
- Test fit all parts before gluing.
- Check off each step as you complete it.

## Construction Supplies Required:

- |             |                      |
|-------------|----------------------|
| A. Ruler    | F. Sandpaper         |
| B. Knife    | G. Paint             |
| C. Pencil   | H. Sanding Sealer    |
| D. Glue     | I. Adult Supervision |
| E. Scissors |                      |

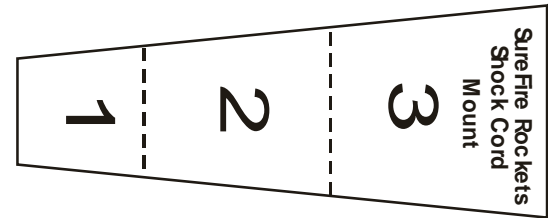

H) Shock Cord Mount

## 1. Engine Mount Assembly

Parts Needed: Engine Mount Tube (H), Engine Hook (G), 2 Centering Rings (F)

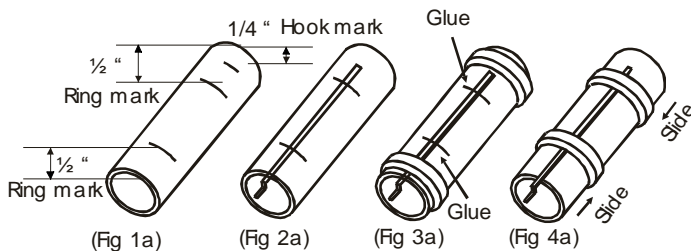

- ❑ Measure and mark  $\frac{1}{4}$ " from the end of the engine tube (H) with a pencil. (Fig 1a)
- ❑ With a hobby knife make a small  $\frac{1}{8}$ " horizontal slit on the mark. Lay the Engine hook (G) on the body tube inserting the 90 degree bent section into the slit. (Fig 2a)
- ❑ Measure and mark  $\frac{1}{2}$ " from both ends of the Engine Mount Tube (H) with a pencil. (Fig 1a)
- ❑ Place one Centering Ring (F) at the top of the Engine Mount Tube (H) and one at the bottom of the Engine Mount Tube (H) as shown. (Fig 3a)
- ❑ Place a small ring of glue around the Engine Mount Tube (H) at both marks you made ( $\frac{1}{2}$ " from the ends) (Fig 3a)
- ❑ Slide the remaining Centering Ring (F) over the glue onto the marks as shown. (Fig 4a)

## 2. Tube Marking

Parts Needed: Main Body Tube (C)

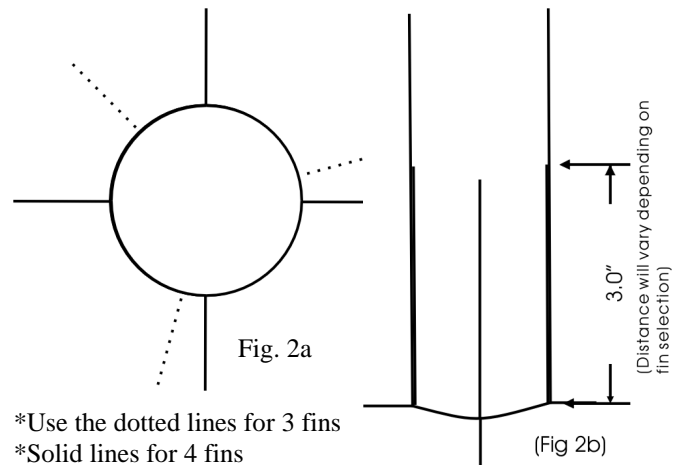

\*Use the dotted lines for 3 fins

\*Solid lines for 4 fins

- ❑ Place the Body Tube (C) on the template. (Fig 2a)
- ❑ With a pencil carefully draw small alignment marks at the intersection of the tube and the fin guide. (Fig 2a)
- ❑ Using a door frame or a tube marking guide (to make straight lines) extend the four fin alignment marks 3" down the Body Tube (C). (Fig 2b)

**\*\* NOTE \*\* Make sure not to press too hard on the tube. A light mark is all that is required**

### 3. Fin Cutting and Preparation

Parts Needed: Fin stock/ PDF fin printout, sandpaper, knife

- ❑ Go online to <http://www.hobbylinc.com/htm/sfr/sfr710180.htm>
- ❑ Select one of the fin configurations
- ❑ Print off the PDF file containing the fin design.
- ❑ Follow the instructions printed with the PDF file for cutting out your fins.

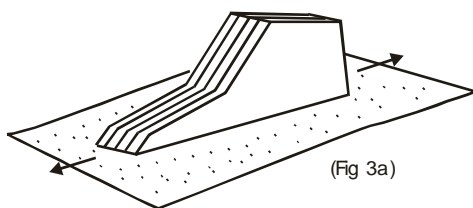

(Fig 3a)

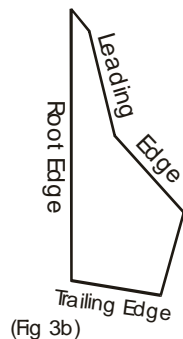

(Fig 3b)

\*Fin configuration will vary

- ❑ Lay your piece of sandpaper rough side up on a table.
- ❑ Align all four Fins (E) together.
- ❑ Lightly sand all edges so that they are equally smooth.

\*\*\*OPTIONAL\*\*\* For even better performance sand the leading edges round and taper the trailing edge.

### 4. Shock Cord Mount Assembly

Parts Needed: Shock Cord (D), Shock Cord Mount (H), Glue.

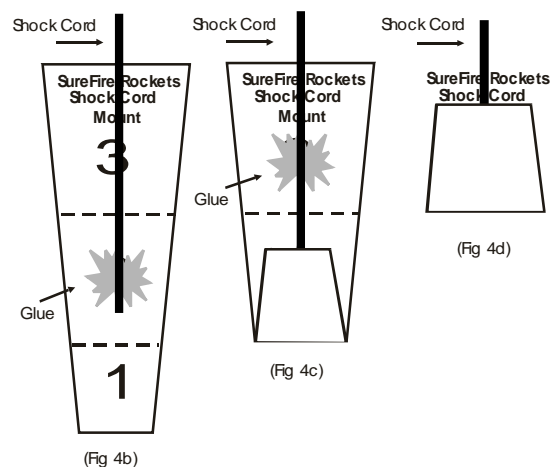

- ❑ Cut out the Shock Cord Mount (H) from the back of this sheet.
- ❑ Lay the Elastic Shock Cord (D) on the mount so that the cord starts on section #2 and lays across section #3. (Fig 4b)
- ❑ Glue the cord to the mount on section #2 (Fig 4b) Fold section #1 onto section #2. Hold till glue dries. (Fig 4c)
- ❑ Glue the cord to section #3 (Fig 4c). Fold sections #1 and #2 on to section #3 (Fig 4d). Hold until glue is dry.

### 5. Engine Mount Installation

Parts Needed: Body Tube (C), Assembled Engine Mount, Glue.

(Fig 5a)

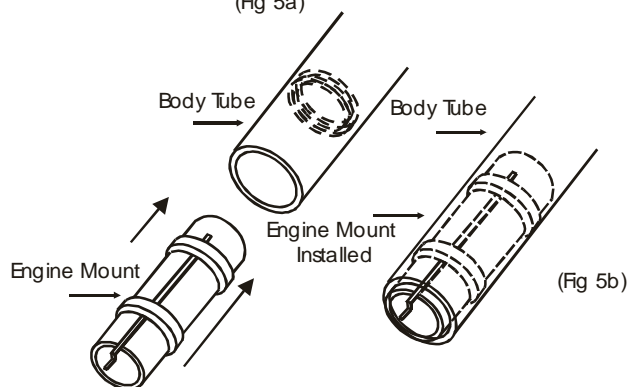

- ❑ The engine mount assembly should be completely dry before starting this step.
- ❑ Locate the end of the tube that has the fin markings. This is the end that the engine mount will be glued to.
- ❑ With a glue applicator (small stick, pencil, your finger, etc...) place a ring of glue about 1 1/2" from the bottom of the tube **on the inside**. (Fig 5a)
- ❑ Slide the assembled engine mount into the body tube until the engine tube (H) is flush with the bottom of the body tube. (C) The completed engine mount should look similar to figure 5b.

### 6. Fin Attachment

Parts Needed: Fins (E), Body Tube (C), Glue (Fin design will vary)

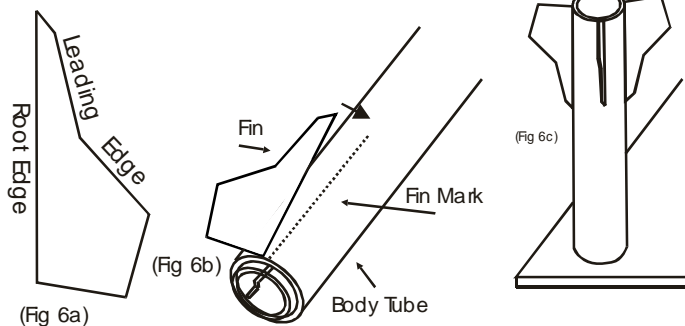

- ❑ Apply a small bead of glue along the root edge of the fin. (Fig 6a).
- ❑ Set the rear edge (trailing edge) of the fin even with the bottom of the body tube. Make sure you are using the end that has the engine mount installed.
- ❑ Press the fin gently against the body tube making sure that the root edge is aligned with one of your marked 3" fin guide lines made in step 3.
- ❑ Carefully adjust the fin as needed to make sure the fin is aligned. An incorrectly placed fin will drastically change the flight of your rocket. Hold the fin in place until the glue is set.
- ❑ Carefully repeat the above steps for each fin. (4)
- ❑ Stand rocket to allow for proper glue drying. (Fig 6c)

## 7. Launch Lug Attachment

Parts Needed: Body Tube (C), Launch Lug (I), Glue, Ruler, Pencil

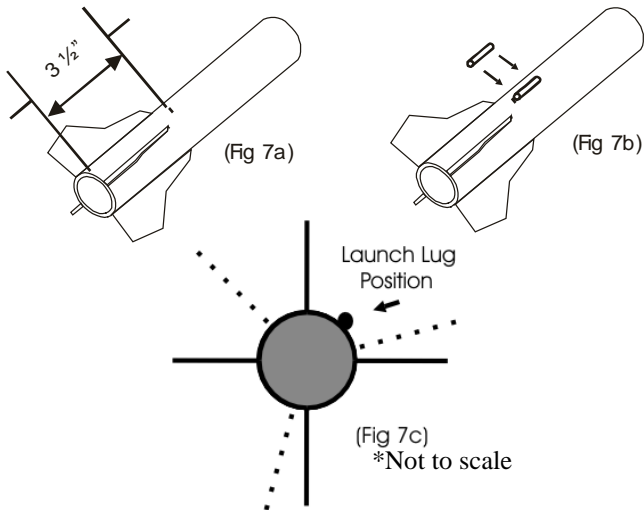

- Measure and mark from the bottom of the rocket (where the fins are) 3 1/2" as a reference line. (Fig 7a) Use this line as a starting point for the Launch Lug (I).
- Apply glue and attach the Launch Lug (I). (fig 7b)
- Make sure that the Launch Lug (I) is aligned with the Body Tube (C) as shown. (Fig 7c) Let dry.

## 8. Fin Reinforcement

Parts Needed: Glue, Rocket frame

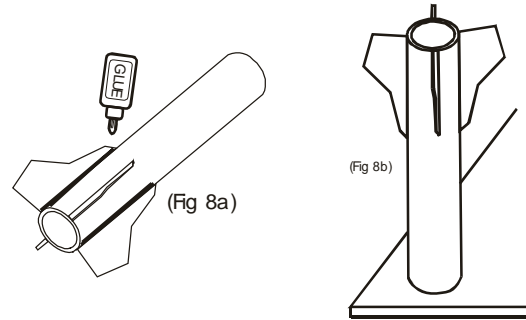

- Filling in the 'gap' between the fins and the rocket tube is important. It improves the aerodynamics of your rocket while improving the strength of your fins.
- Take a bead of glue and run along the fins where they join the body tube. (Fig 8a) Glue only one fin at a time.
- Smooth the glue into the gap creating a fillet of glue between the fins and the tube.
- Stand the rocket as shown (Fig 8b) to allow the glue to dry.

## 9. Shock Cord Mount Attachment

Parts Needed: Rocket, Shock Cord/ Attached Mount

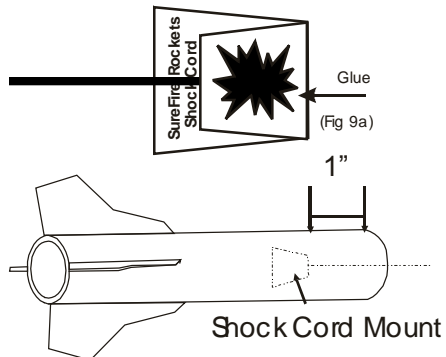

- Apply glue to the shock cord-mount (Fig 9a) and insert into the rocket tube. (Fig 9b)
- Make sure you place the mount at least 1" from the top of the body tube. This space is needed for the nose cone to fit.
- Press the mount firmly to the tube with your finger or a small rod. Hold mount until glue sets.

\*\*\*NOTE\*\*\* Before you launch your rocket, lightly pull on the shock cord to make sure it is firmly attached. A bad gluing job here could mean only one flight for your rocket.

## 10. Attach Your Nose Cone

Parts Needed: Shock Cord (attached), Nose Cone (B), Streamer (A)

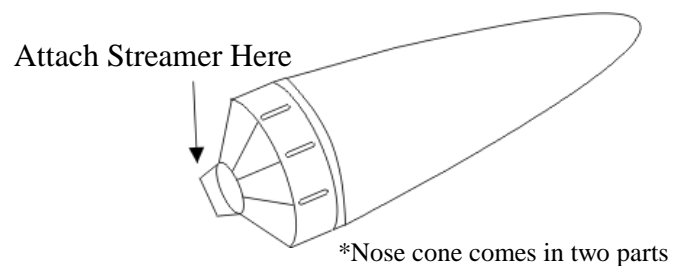

- Glue on the cap of the nose cone. Follow the drying instructions provided by the type of glue you are using. It is very important to let the glue fully dry.
- Tie the Shock Cord to the Nose Cone (B) at the location shown above. (Fig 10a) Tie a triple knot in the shock cord to ensure that it does not come untied during flight
- Tie Streamer (A) to the same location as the shock cord as shown above (Fig 10a) Again, triple knot your streamer so that it has no chance of un-tying during flight.
- Congratulations! You're done building your rocket. You can prepare it for flight now (Step #12) or proceed to painting and decorating (Step #11).

## 11. Painting your Rocket

Parts Needed: Assembled Rocket. Colors.

Painting and detailing your new rocket is a personal choice. You can paint the rocket with any hobby quality acrylic or enamel paint. Additionally the rocket can be colored with markers.

### Tips on painting or coloring your rocket:

1. When spraying your rocket make sure to keep the spray can 12 inches from the rocket.
2. Make long sweeping strokes starting before the part you are painting and stopping after.
3. Only do one coat at a time. Several thin coats are better than one thick coat that will run.
4. Make sure to paint outside or in a well ventilated area.
5. Adult supervision is required for children under 10 for painting.
6. Adult supervision is recommend for all children under 8 using markers to color their rocket.

## 13. Launch Supplies

### To launch your rocket you will need the following items:

- ❑ A Launch controller and Launch pad with a 1/8" launch rod.
- ❑ Three to four sheets of recovery wadding for each additional flight.
- ❑ Recommended engines: A8-3, B4-2, B4-4, B4-6, B6-2, B6-4, B6-6, C6-3, C6-5, C6-7, C5-3
- ❑ It is recommended that you use smaller engines such as the A8-3 for your first flight in order to check your rockets flight pattern.

## 14. Rocket Flight

Choose a large field with no power lines or trees. Try to find a field that is at least 650 feet square. The larger the field the less rockets lost. Launch your rocket during calm days only. If windy make sure you aim your rocket into the wind to adjust for drift after the recovery device has been deployed.

Always make sure to follow any local laws and the NAR model rocketry safety code.

## 12. You are Done!!

**Congratulations on successfully building your SureFire Rocket!** Please take a minute to read the following pre-flight information to ensure a successful flight of your rocket.

### Preparing your rocket for Flight.

- ❑ Crumple and insert three to four sheets of wadding into the nosecone end of your rocket.
- ❑ Push the wadding inside the body tube using a pencil or pen.
- ❑ Fold the streamer in three-inch lengths and insert into your body tube.  
\*\* NOTE \*\* Streamer and wadding should fit loosely into the tube.
- ❑ Stick the remaining shock cord in the tube and insert the nose cone.

### Preparing your Engine for Flight.

- ❑ Holding your engine upright insert the igniter until it makes contact with the propellant. (This is usually about 1/4 to 1/2 inch).
- ❑ Insert igniter plug into the engine. Firmly push the plug all the way in.
- ❑ Bend igniter wires back and insert the engine into your rocket.
- ❑ Your rocket is now ready for flight!

## 15. Rocket Launch

1. **Make sure the safety key is not in the launch controller.**
2. Slide your rocket onto the launch pad making sure the launch lug slides freely over the launch rod.
3. Attach the wires from the launch controller to your igniter. Make sure the clips are separated (for Estes igniters) and not touching the blast deflector plate.
4. Make sure everyone is at least 15 feet back from the launch pad.
5. Insert the safety key and depress it so the light comes on.

### **Give an audible countdown**

**5.....4.....3.....2.....1....BLAST OFF !!!!**

( press the button )